















Poltrona **A R A T U**





Poltrona **A R A T U**

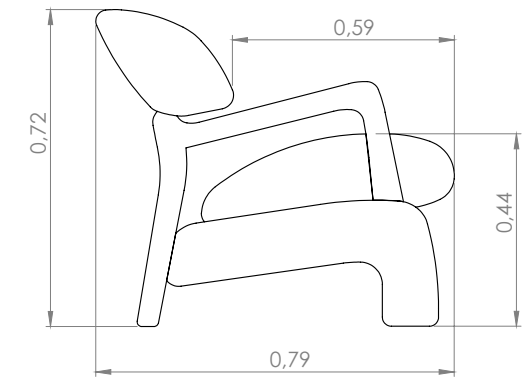
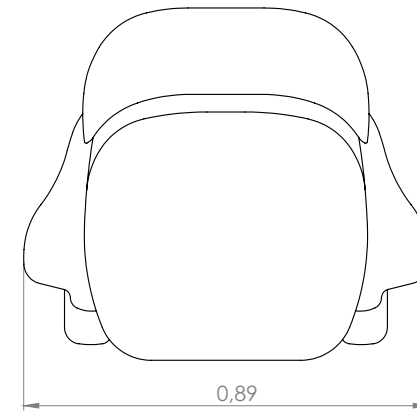

**SEAT:** FIXED – D28 + FIBER

**BACKREST:** FIXED – D28 + FIBER

**STRUCTURE:** DYEINGS – EBANIZED, IMBUIA, LINEN,  
WALNUT, NATURAL

**WOOD:** TAUARI

**OBSERVATIONS:** LINEN AND NATURAL DYES  
HIGHLIGHT THE NATURAL CHARACTERISTICS OF  
WOOD, AND MAY SHOW DIFFERENCES IN TONES

**ASIENTO:** FIJO – D28 + FIBER

**RESPALDO:** FIJO - D28 + FIBRA

**ESTRUCTURA:** TINTURAS - ÉBANO, IMBUIA, LINO,  
NOGAL, NATURALES Y NUECES

**MADERA:** TAUARI

**OBSERVACIONES:** EL LINO Y LOS TINTES NATURALES  
RESALTAN LAS CARACTERÍSTICAS NATURALES DE  
LA MADERA Y PUEDEN MOSTRAR DIFERENCIAS DE  
TONOS





Poltrona

# FURADA





Poltrona

# FURADA

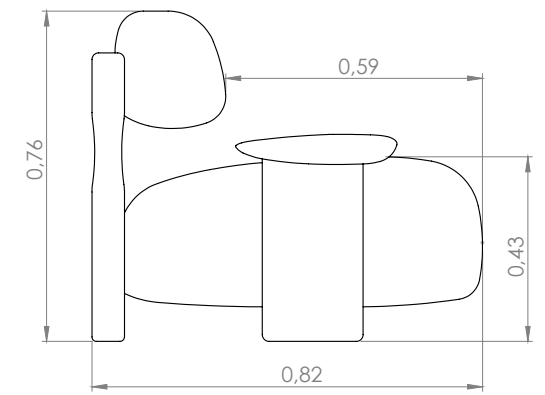
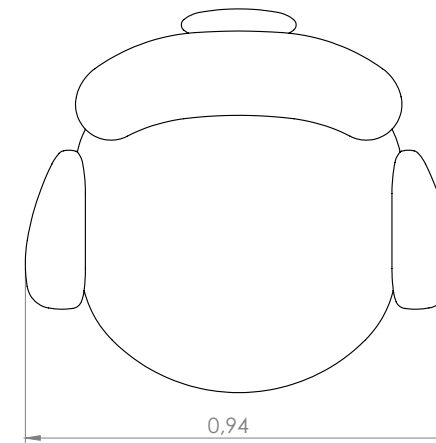

**SEAT:** FIXED – D28 + FIBER

**BACKREST:** FIXED – D28 + FIBER

**STRUCTURE:** DYEINGS – EBANIZED, IMBUIA, LINEN,  
WALNUT, NATURAL

**WOOD:** TAUARI

**OBSERVATIONS:** LINEN AND NATURAL DYES  
HIGHLIGHT THE NATURAL CHARACTERISTICS OF  
WOOD, AND MAY SHOW DIFFERENCES IN TONES

**ASIENTO:** FIJO – D28 + FIBER

**RESPALDO:** FIJO - D28 + FIBRA

**ESTRUCTURA:** TINTURAS - ÉBANO, IMBUIA, LINO,  
NOGAL, NATURALES Y NUECES

**MADERA:** TAUARI

**OBSERVACIONES:** EL LINO Y LOS TINTES NATURALES  
RESALTAN LAS CARACTERÍSTICAS NATURALES DE  
LA MADERA Y PUEDEN MOSTRAR DIFERENCIAS DE  
TONOS





G O T A





Poltrona

G O T A

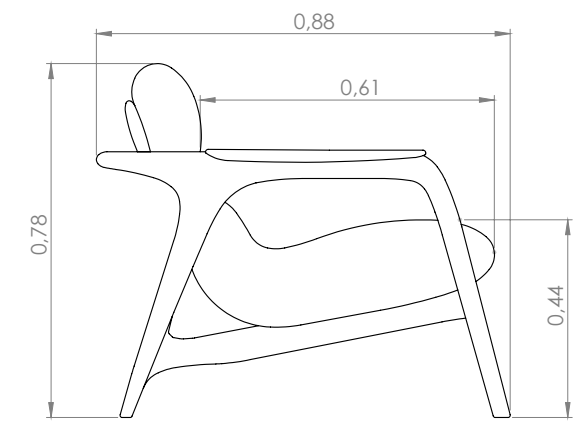
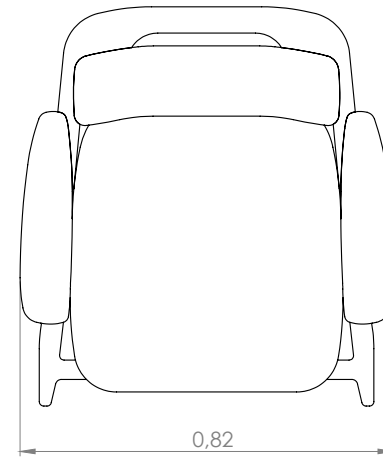

**SEAT:** FIXED – D28 + FIBER

**BACKREST:** FIXED – D28 + FIBER

**STRUCTURE:** DYEINGS – EBANIZED, IMBUIA, LINEN,  
WALNUT, NATURAL

**WOOD:** TAUARI

**OBSERVATIONS:** LINEN AND NATURAL DYES  
HIGHLIGHT THE NATURAL CHARACTERISTICS OF  
WOOD, AND MAY SHOW DIFFERENCES IN TONES

**ASIENTO:** FIJO – D28 + FIBER

**RESPALDO:** FIJO - D28 + FIBRA

**ESTRUCTURA:** TINTURAS - ÉBANO, IMBUIA, LINO,  
NOGAL, NATURALES Y NUECES

**MADERA:** TAUARI

**OBSERVACIONES:** EL LINO Y LOS TINTES NATURALES  
RESALTAN LAS CARACTERÍSTICAS NATURALES DE  
LA MADERA Y PUEDEN MOSTRAR DIFERENCIAS DE  
TONOS





Poltrona

# DRUMMOND





Poltrona

# DRUMMOND

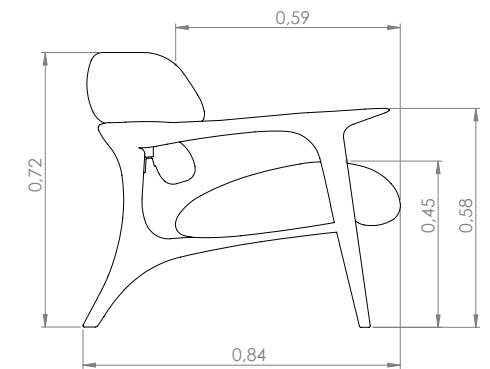
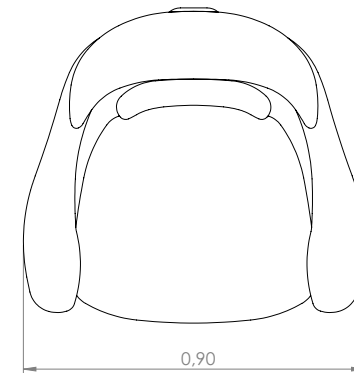

**SEAT:** FIXED + D28+ FIBER

**BACKREST:** FIXED + D28 + FIBER

**LUMBAR CUSHION:** FIXED + D28 + FIBER

**STRUCTURE:** DYEINGS - LINEN, WALNUT, EBANIZED,  
NATURAL, IMBUIA AND WALNUTS

**WOOD:** TAUARI

**OBSERVATIONS:** LINEN AND NATURAL DYES

HIGHLIGHT THE NATURAL CHARACTERISTICS OF  
WOOD, AND MAY SHOW DIFFERENCES IN TONES

**ASIENTO:** FIJO + D28 + FIBRA

**RESPALDO:** FIJO + FIBRA + D28

**ALMOHADA ESPALDA BAJA:** FIJO + FIBRA + D28

**ESTRUCTURA:** TINTURAS - LINO, NOGAL, EBANIZADOS,  
NATURALES, IMBUIA Y NUECES

**MADERA:** TAUARI

**OBSERVACIONES:** EL LINO Y LOS TINTES NATURALES

RESALTAN LAS CARACTERÍSTICAS NATURALES DE  
LA MADERA Y PUEDEN MOSTRAR DIFERENCIAS DE  
TONOS







Poltrona  
e Puff

# U R U C U M





# URUCUM

**SEAT:** FIXED + D28 + FIBER

**BACKREST:** FIXED + D28 + FIBER

**LUMBAR CUSHION:** FIXED + D28 + FIBER

**STRUCTURE:** DYEINGS - LINEN, WALNUT, EBANIZED,  
NATURAL, IMBUIA AND WALNUTS

**WOOD:** TAUARI

**OBSERVATIONS:** LINEN AND NATURAL DYES  
HIGHLIGHT THE NATURAL CHARACTERISTICS OF  
WOOD, AND MAY SHOW DIFFERENCES IN TONES

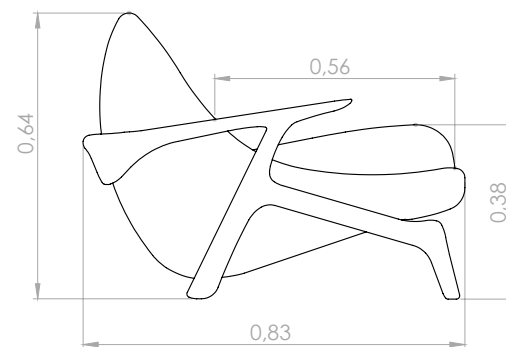
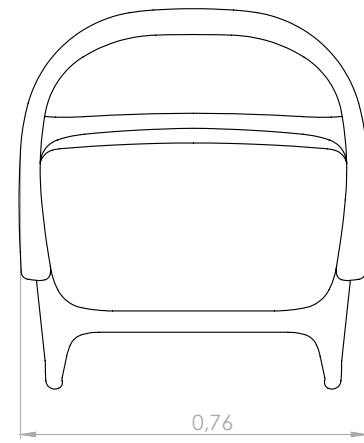

**ASIENTO:** FIJO + D28 + FIBRA

**RESPALDO:** FIJO + D28 + FIBRA

**ALMOHADA ESPALDA BAJA:** FIJO + D28 + FIBRA

**ESTRUCTURA:** TINTURAS - LINO, NOGAL, EBANIZADOS,  
NATURALES, IMBUIA Y NUECES

**MADERA:** TAUARI

**OBSERVACIONES:** EL LINO Y LOS TINTES NATURALES  
RESALTAN LAS CARACTERÍSTICAS NATURALES DE  
LA MADERA Y PUEDEN MOSTRAR DIFERENCIAS DE  
TONOS

**SEAT:** FIXED + D28+ FIBER

**STRUCTURE:** DYEINGS - LINEN, WALNUT, EBANIZED,  
NATURAL, IMBUIA AND WALNUTS

**WOOD:** TAUARI

**OBSERVATIONS:** LINEN AND NATURAL DYES  
HIGHLIGHT THE NATURAL CHARACTERISTICS OF  
WOOD, AND MAY SHOW DIFFERENCES IN TONES

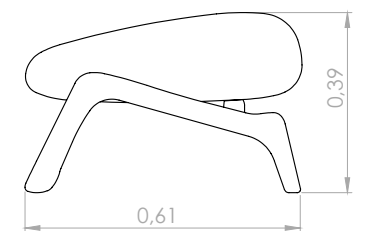
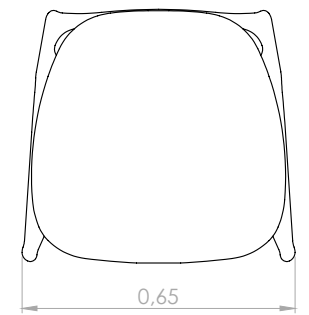

**ASIENTO:** FIJO + D28+ FIBRA

**ESTRUCTURA:** TINTURAS - LINO, NOGAL, EBANIZADOS,  
NATURALES, IMBUIA Y NUECES

**MADERA:** TAUARI

**OBSERVACIONES:** EL LINO Y LOS TINTES NATURALES  
RESALTAN LAS CARACTERÍSTICAS NATURALES DE  
LA MADERA Y PUEDEN MOSTRAR DIFERENCIAS DE  
TONOS





STALK







Cadeira

# STALK

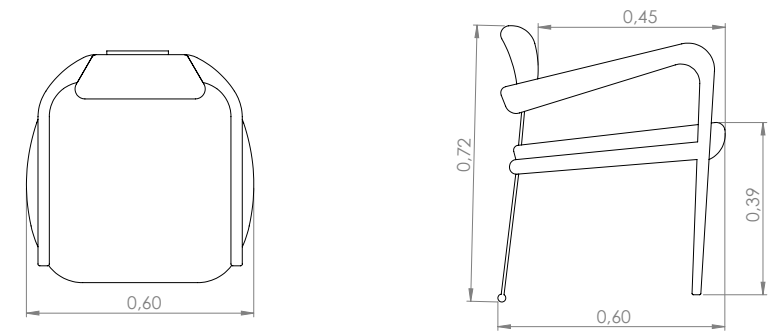

**SEAT:** FIXED + D28+ FIBER

**BACKREST:** FIXED + D28 + FIBER

**FOOT/BASE:** ELECTROSTATIC PAINTING - BLACK,  
BROWN, LEAD AND NUDE

**STRUCTURE:** DYEINGS - LINEN, WALNUT, EBANIZED,  
NATURAL, IMBUIA AND WALNUTS

**WOOD:** TAUARI

**OBSERVATIONS:** LINEN AND NATURAL DYES  
HIGHLIGHT THE NATURAL CHARACTERISTICS OF  
WOOD, AND MAY SHOW DIFFERENCES IN TONES

**SEAT:** FIXED + D28+ FIBER

**BACKREST:** FIXED + D28 + FIBER

**FOOT/BASE:** ELECTROSTATIC PAINTING - BLACK, BROWN,  
LEAD AND NUDE

**STRUCTURE:** DYEINGS - LINEN, WALNUT, EBANIZED,  
NATURAL, IMBUIA AND WALNUTS

**WOOD:** TAUARI

**OBSERVATIONS:** EL LINO Y LOS TINTES NATURALES  
RESALTAN LAS CARACTERÍSTICAS NATURALES DE LA  
MADERA Y PUEDEN MOSTRAR DIFERENCIAS DE TONOS







Poltrona

STALK





Poltrona **S T A L K**

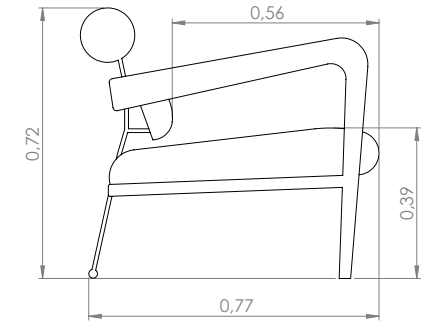
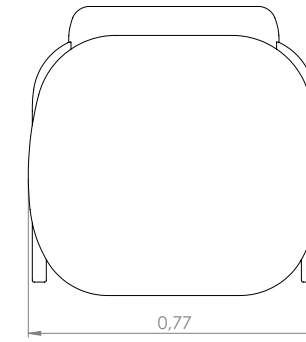

**SEAT:** FIXED + D28 + FIBER

**BACKREST:** FIXED + D28 + FIBER

LUMBAR CUSHION: FIXED + D28 + FIBER

**FOOT/BASE:** ELECTROSTATIC PAINTING - BLACK,  
BROWN, LEAD AND NUDE

**STRUCTURE:** DYEINGS - LINEN, WALNUT, EBANIZED,  
NATURAL, IMBUIA AND WALNUTS

**WOOD:** TAUARI

**OBSERVATIONS:** LINEN AND NATURAL DYES  
HIGHLIGHT THE NATURAL CHARACTERISTICS OF  
WOOD, AND MAY SHOW DIFFERENCES IN TONES

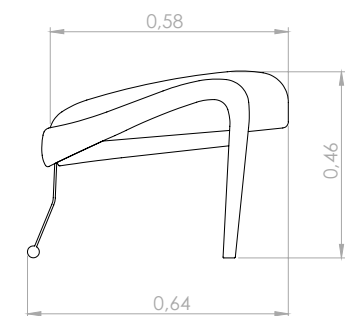

**ASIENTO:** FIJO + D28 + FIBRA

**RESPALDO:** FIJO + D28 + FIBRA

**ALMOHADA ESPALDA BAJA:** FIJO + D28 + FIBRA

**PIE/BASE:** PINTURA ELECTROSTÁTICA - NEGRA, MARRÓN,  
PLOMO Y NUDE

**ESTRUCTURA:** TINTURAS - LINO, NOGAL, EBANIZADOS,  
NATURALES, IMBUIA Y NUECES

**MADERA:** TAUARI

**OBSERVACIONES:** EL LINO Y LOS TINTES NATURALES  
RESALTAN LAS CARACTERÍSTICAS NATURALES DE LA  
MADERA Y PUEDEN MOSTRAR DIFERENCIAS DE TONOS



POLTRONA

POLTRONA

STALK



STALK



BANCO

BANCO

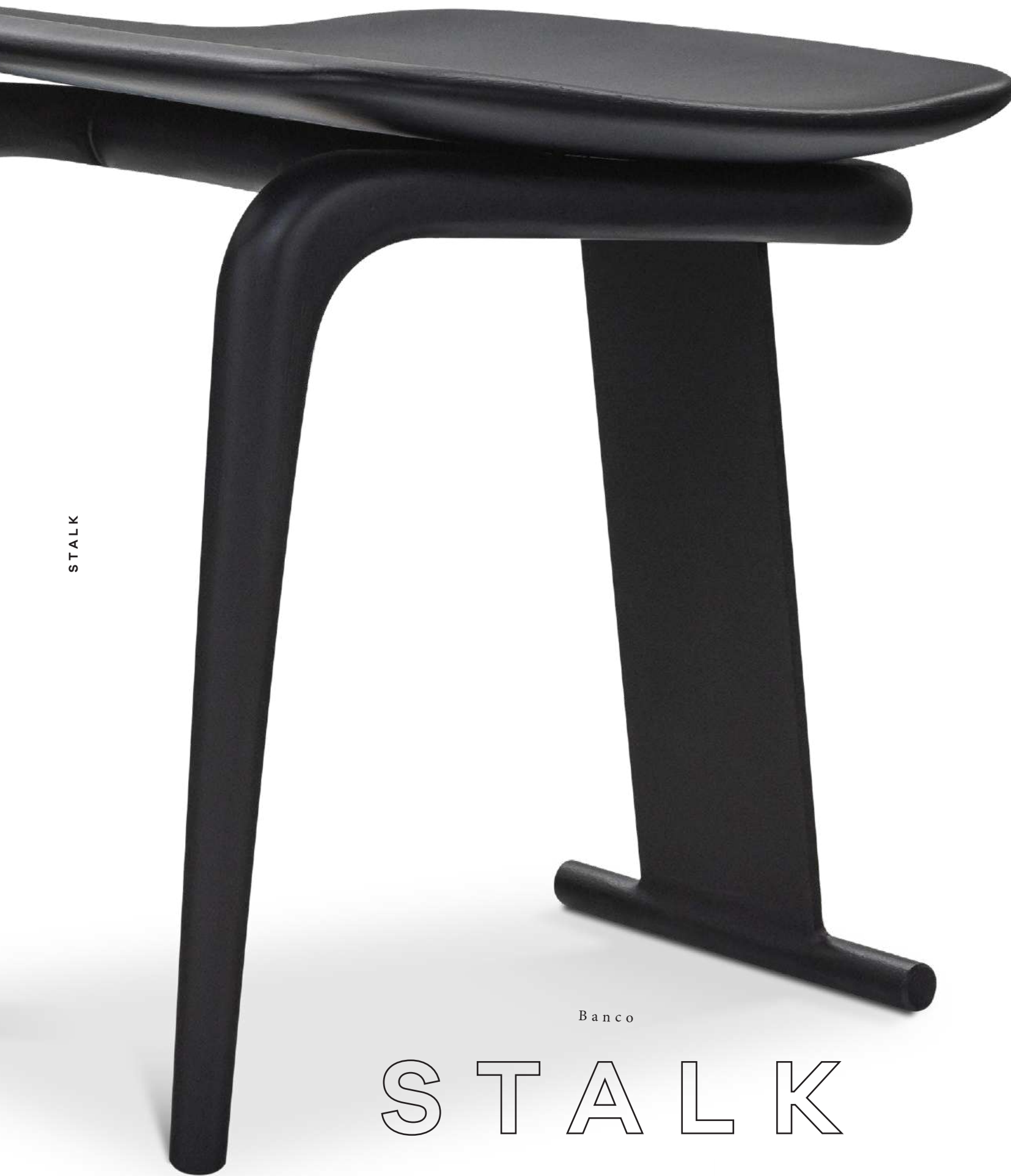

STALK



STALK

Banco

STALK



Banco

# STALK



**SEAT:** WOOD

**FOOT/BASE:** ELECTROSTATIC PAINTING - BLACK, BROWN, LEAD AND NUDE

**STRUCTURE:** DYEINGS - LINEN, WALNUT, EBANIZED, NATURAL, IMBUIA AND WALNUTS

**WOOD:** TAUARI

**OBSERVATIONS:** LINEN AND NATURAL DYES HIGHLIGHT THE NATURAL CHARACTERISTICS OF WOOD, AND MAY SHOW DIFFERENCES IN TONES

**ASIENTO:** MADERA

**PIE/BASE:** PINTURA ELECTROSTÁTICA - NEGRA, MARRÓN, PLOMO Y NUDE

**ESTRUCTURA:** TINTURAS - LINO, NOGAL, EBANIZADOS, NATURALES, IMBUIA Y NUECES

**MADERA:** TAUARI

**OBSERVACIONES:** EL LINO Y LOS TINTES NATURALES RESALTAN LAS CARACTERÍSTICAS NATURALES DE LA MADERA Y PUEDEN MOSTRAR DIFERENCIAS DE TONOS

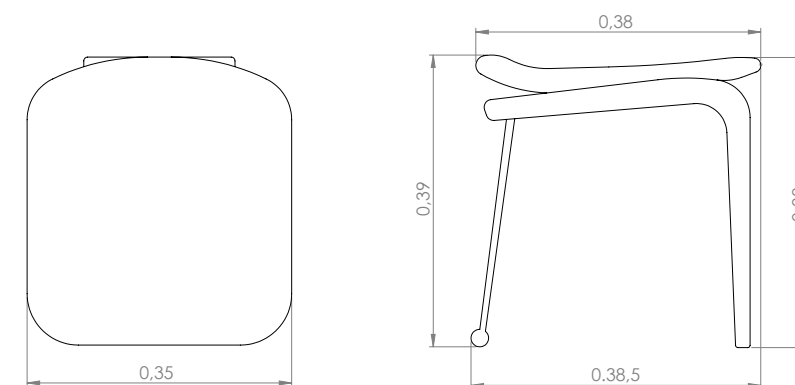





Banqueta

STALK



Banqueta

# STALK

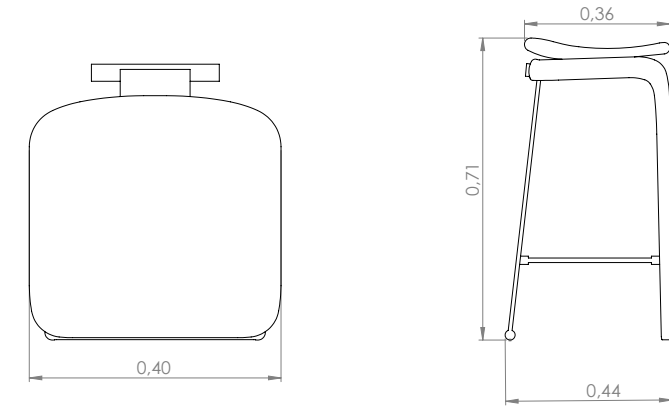

**SEAT:** WOOD

**FOOT/BASE:** ELECTROSTATIC PAINTING - BLACK, BROWN, LEAD AND NUDE

**STRUCTURE:** DYEINGS - LINEN, WALNUT, EBANIZED, NATURAL, IMBUIA AND WALNUTS

**WOOD:** TAUARI

**OBSERVATIONS:** LINEN AND NATURAL DYES

HIGHLIGHT THE NATURAL CHARACTERISTICS OF WOOD, AND MAY SHOW DIFFERENCES IN TONES

**ASIENTO:** MADERA

**PIE/BASE:** PINTURA ELECTROSTÁTICA - NEGRA, MARRÓN, PLOMO Y NUDE

**ESTRUCTURA:** TINTURAS - LINO, NOGAL, EBANIZADOS, NATURALES, IMBUIA Y NUECES

**MADERA:** TAUARI

**OBSERVACIONES:** EL LINO Y LOS TINTES NATURALES

RESALTAN LAS CARACTERÍSTICAS NATURALES DE LA MADERA Y PUEDEN MOSTRAR DIFERENCIAS DE TONOS







Poltrona

EREDITA



Poltrona

# EREDITA

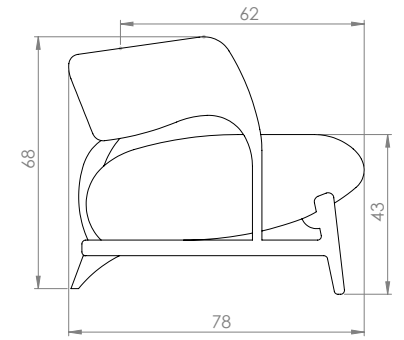
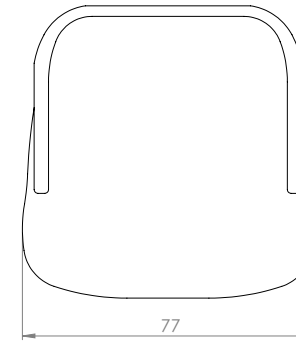

**SEAT:** FIXED + D28+ FIBER

**BACKREST:** FIXED + D28 + FIBER

**STRUCTURE:** DYEINGS - LINEN, WALNUT, EBANIZED,  
NATURAL, IMBUIA AND WALNUTS

**WOOD:** TAUARI

**OBSERVATIONS:** LINEN AND NATURAL DYES  
HIGHLIGHT THE NATURAL CHARACTERISTICS OF  
WOOD, AND MAY SHOW DIFFERENCES IN TONES



**ASIENTO:** FIJO + D28 + FIBRA

**RESPALDO:** FIJO + D28 + FIBRA

**ESTRUCTURA:** TINTURAS - LINO, NOGAL, EBANIZADOS,  
NATURALES, IMBUIA Y NUECES

**MADERA:** TAUARI

**OBSERVACIONES:** EL LINO Y LOS TINTES NATURALES  
RESALTAN LAS CARACTERÍSTICAS NATURALES DE LA  
MADERA Y PUEDEN MOSTRAR DIFERENCIAS DE TONOS





Poltrona

# LONGEVA

Por Mauricio Bomfim



Poltrona

# L O N G E V A

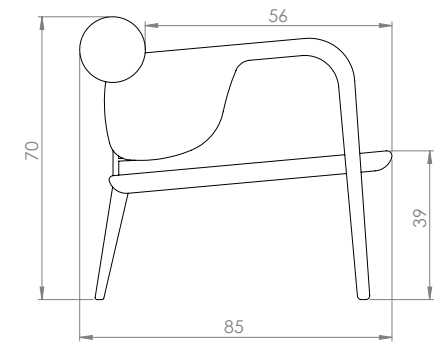
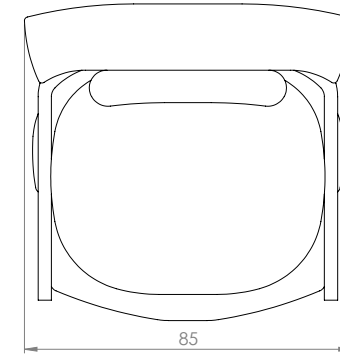

**SEAT:** FIXED + D28 + FIBER

**BACKREST:** FIXED + D28 + FIBER

**LUMBAR CUSHION:** FIXED + D28 + FIBER

**STRUCTURE:** DYEINGS - LINEN, WALNUT, EBANIZED,  
NATURAL, IMBUIA AND WALNUTS

**WOOD:** TAUARI

**OBSERVATIONS:** LINEN AND NATURAL DYES

HIGHLIGHT THE NATURAL CHARACTERISTICS OF  
WOOD, AND MAY SHOW DIFFERENCES IN TONES

**ASIENTO:** FIJO + D28 + FIBRA

**RESPALDO:** FIJO + D28 + FIBRA

**ALMOHADA ESPALDA BAJA:** FIJO + D28 + FIBRA

**ESTRUCTURA:** TINTURAS - LINO, NOGAL, EBANIZADOS,  
NATURALES, IMBUIA Y NUECES

**MADERA:** TAUARI

**OBSERVACIONES:** EL LINO Y LOS TINTES NATURALES

RESALTAN LAS CARACTERÍSTICAS NATURALES DE LA  
MADERA Y PUEDEN MOSTRAR DIFERENCIAS DE TONOS





POLTRONA

POLTRONA



RITUAL

RITUAL

RITUAL

Poltrona **RITUAL**

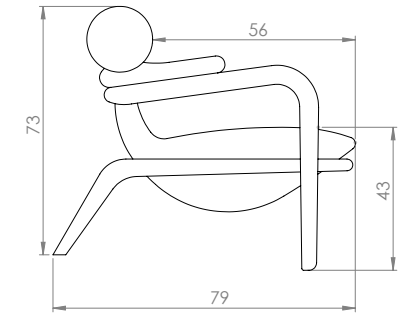
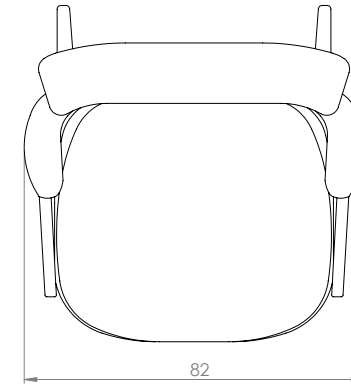

**SEAT:** FIXED + D28+ FIBER

**BACKREST:** FIXED + D28 + FIBER

**STRUCTURE:** DYEINGS - LINEN, WALNUT, EBANIZED,  
NATURAL, IMBUIA AND WALNUTS

**WOOD:** TAUARI

**OBSERVATIONS:** LINEN AND NATURAL DYES  
HIGHLIGHT THE NATURAL CHARACTERISTICS OF  
WOOD, AND MAY SHOW DIFFERENCES IN TONES

**ASIENTO:** FIJO + D28 + FIBRA

**RESPALDO:** FIJO + D28 + FIBRA

**ESTRUCTURA:** TINTURAS - LINO, NOGAL, EBANIZADOS,  
NATURALES, IMBUIA Y NUECES

**MADERA:** TAUARI

**OBSERVACIONES:** EL LINO Y LOS TINTES NATURALES  
RESALTAN LAS CARACTERÍSTICAS NATURALES DE LA  
MADERA Y PUEDEN MOSTRAR DIFERENCIAS DE TONOS





